

**ENT UNIT Mod. OTOCOMPACT PROFESSIONAL EVO 2.0**



**UNIQUE FEATURES:**

- **ELECTRICALLY-OPERATED DRAWERS** - Absolute innovation in the medical field with the application of electrical motors to all unit's drawers granting a soft and silent opening and closing by a simple touch pressure through the **SERVO-DRIVE** and the **BLUMOTION** systems
- **COLOR TOUCH SCREEN 7"**
- **INSTRUMENTS TABLET on ARTICULATED ARM with OPTICAL SENSORS**
- **DUAL CONTROL SYSTEM** – WIRELESS system from touch screen for the combined 3 or 4 motors patient chair's movements plus the recall of 3 memories and 0 position (resting position)
- **COLUMN -MADE DRAWERS** with:
  - 1 compartment to storage instruments
  - 1 compartment for used instruments with letter-box opening
  - 1 compartment for waste bin
- **MOBILE ON WHEELS**
- **ONLY CONNECTION TO POWER SUPPLY NEEDED**

**THE UNIT IS PROVIDED WITH THE FOLLOWING APPLICATIONS (Included in the standard version of the unit):**

- **Working Top in Glass** – color at your choice among 20 nuances available
- Drawers combination with **UV germicide compartment + n.2 Drawers to storage instruments with frontal parts in colored glass** color at your choice among 20 nuances available
- Powerful Suction System complete with **oil pump with 70 Lt/min** capacity –
- Kit of 6 **stainless steel suction cannulas**;
- Multi use **canister of 2 lt.** capacity
- **Antimicrobial Filter**
- Head Lamp Fixed Supports (2 SUPPORTS)

**MEDI-CARE SOLUTIONS S.R.L**

SEDE LEGALE: Via Della Zecca N° 1 - 40121 Bologna (BO) Italy;  
SEDE OPERATIVA: Via Pietro Nenni 3 - 40026 Imola (BO)- Italy; Tel. ++39 0542 642046 Fax ++39 0542 642355  
WEBSITE: [www.euroclinic.it](http://www.euroclinic.it) - E-MAIL: [info@euroclinic.it](mailto:info@euroclinic.it)  
Capitale Sociale: € 50.000,00 i.v. - Iscrizione N° 03390661209 al Registro Imprese Bologna - P.I. e C.F. 03390661209  
R.E.A. N° 515493 - VAT 03390661209 - Registro AEE N° iscrizione IT506000008925- N° MECC. BO056722

Azienda con Sistema di qualità certificato UNI EN ISO 9001:2015 and UNI EN ISO 13485:2021  
Company with Quality System Certificate UNI EN ISO 9001:2015 and UNI EN ISO 13485:2021

- **Insufflation System** (Nr. 2 POLITZER olives included)
- **Compressed Air System** for medicaments
- **Auricular-washing syringe** Microprocessor-controlled heating element set at 37° C.
- **Larynx Mirror Warmer**
- Nr. 2 Fixed support for headlight
- **Nr. 4 LED LIGHT SOURCES** 5.500°K – 200 Lumen – as follows
  - **Nr. 1 LED LIGHT SOURCE WITH HANDPIECE** direct connection to endoscopes
  - **Nr. 3 LED LIGHT SOURCES WITH OUTLETS for F.O. cables complete with nr. 3 F.O. CABLES** L= 1800 mm – diam. 3,5 mm

For all the light sources there is the possibility to control and adjust the light intensity from the unit's touch screen from 0 to 100% - Automatic activation at the extraction of the light source;
- **Nr. 6 ENDOSCOPE SUPPORTS** – 5 holders for rigid endoscopes and N.1 holder for flexible
- **Nr. 2 Heated endoscope supports**
- **Nr. 1 WIRELESS HEADLIGHT by FAROMED ( Germany)**

## OPTIONAL APPLICATIONS :

<b><u>SUCTION APPLICATIONS</u></b> to be selected between		
21104097	Automatic discharge System (as replacement of the 2 lt. multiuse jar already included)	
21104098	Automatic rinsing system for suction tubes	
<b><u>STRUCTURES AND WORKING TOP APPLICATION</u></b> to be selected between		
21104154+ 21104048	<b>Pole support</b> for microscope complete with articulated arm for monitor	
<b><u>CAMERA APPLICATIONS</u></b> to be selected between		
21104121 25502029 56583228 25502012 21104120	Application of <b>HD Camera ED1400</b> already complete with EDM_videocapture Software and PC system NUC I7 with HD monitor 24" and wireless mouse/keyboard + <b>camera keyboard + receiver and wireless foot control for taking snapshot</b>	
21104116+ 21104121+ 21102012	Application of <b>ED420 (1/3CCD) wired camera</b> already complete with EDM_videocapture Software and PC system NUC I7 with HD monitor 24" and wireless mouse/keyboard	
<b><u>MICROSCOPE APPLICATIONS</u></b> to be selected between		
56596001	<b>Zeiss</b> microscope mod. OPMI PICO to be mounted on the unit's pole support;	
56596030	<b>LED</b> application for Zeiss microscope	
56593052	Zeiss <b>endoport</b> , for connecting an external camera	
56596050	<b>Kaps</b> microscope mod. SOM22 with <b>LED light</b> – made in Germany	
56596010	<b>Kaps beam splitter</b> for connecting an external camera	
56596091	<b>Labomed</b> microscope mod. <b>PRIMA</b> (LED light) mounted on unit	
56596093	<b>Labomed beam splitter and Endo Adapter</b>	

### **MEDI-CARE SOLUTIONS S.R.L**

SEDE LEGALE: Via Della Zecca N° 1 - 40121 Bologna (BO) Italy;  
 SEDE OPERATIVA: Via Pietro Nenni 3 - 40026 Imola (BO)- Italy; Tel. ++39 0542 642046 Fax ++39 0542 642355  
 WEBSITE: [www.euroclinic.it](http://www.euroclinic.it) - E-MAIL: [info@euroclinic.it](mailto:info@euroclinic.it)  
 Capitale Sociale: € 50.000,00 i.v. - Iscrizione N° 03390661209 al Registro Imprese Bologna - P.I. e C.F. 03390661209  
 R.E.A. N° 515493 - VAT 03390661209 - Registro AEE N° iscrizione IT506000008925- N° MECC. B0056722

Azienda con Sistema di qualità certificato UNI EN ISO 9001:2015 and UNI EN ISO 13485:2021  
 Company with Quality System Certificate UNI EN ISO 9001:2015 and UNI EN ISO 13485:2021

56596041	Professional examination <b>ZUMAX microscope model OMS2350 with LED light</b> – made in China	
56596043	<b>Zumax beam splitter and camera adapter</b>	
	<b>FLEXIBLE &amp; RIGID SCOPES – TO BE QUOTED ON DEMAND</b>	

Tensione di alimentazione/Power supply tension/Tension d'alimentation électrique	220/240 V (110/115 VAC)
Frequenza /Frequency/Fréquence	50/60 Hz
Potenza assorbita (configurazione MAX)/Absorbed power (MAX configuration)/Puissance absorbée (MAX configuration)	1550 VA
Peso/Weight/Poids	120 Kg
Numero massimo di strumenti/Maimum instruments nr./Nr.maximum des instruments	4
Portata aria insufflatore/Insufflator ait capacity/Capacité d'air insufflateur	26 l/m (variaz. Fino a 250 Kpa)
Portata siringa lavaggi/Washing stringe capacity/Capacité seringue lavages	350/400 cc/min (a 2 Bar)
Aspirazione nominale (motore ad olio)/Nominal suction (oil motor)/Aspiration nominale(moteur à huile)	-86 KPa (-650 mm Hg 50L/min)
Fusibili alimentazione/power supply fuses/Fusibles alimentation électrique	F1,F2 = 6,3A T
Fusibile Presa esterna /Fuse external Plug/Fusible prise de courant externe	F3 =4A T

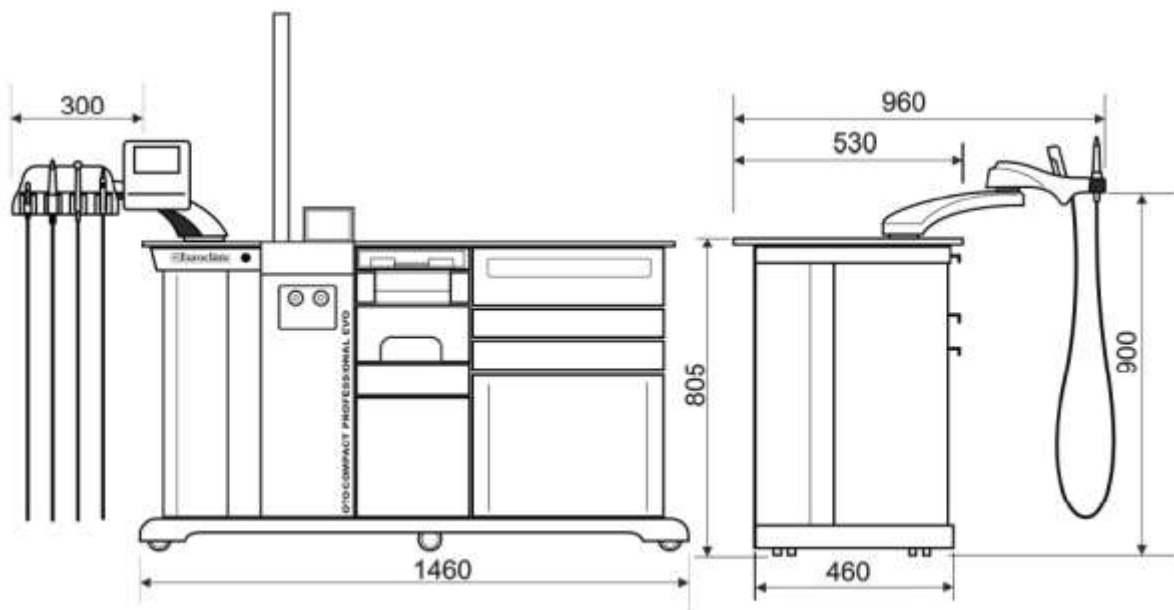

### MEDI-CARE SOLUTIONS S.R.L

SEDE LEGALE: Via Della Zecca N° 1 - 40121 Bologna (BO) Italy;  
 SEDE OPERATIVA: Via Pietro Nenni 3 - 40026 Imola (BO)- Italy; Tel. ++39 0542 642046 Fax ++39 0542 642355

WEBSITE: [www.euroclinic.it](http://www.euroclinic.it) - E-MAIL: [info@euroclinic.it](mailto:info@euroclinic.it)

Capitale Sociale: € 50.000,00 i.v. - Iscrizione N° 03390661209 al Registro Imprese Bologna - P.I. e C.F. 03390661209  
 R.E.A. N° 515493 - VAT 03390661209 - Registro AEE N° iscrizione IT5060000008925- N° MECC. BO056722

Azienda con Sistema di qualità certificato UNI EN ISO 9001:2015 and UNI EN ISO 13485:2021  
 Company with Quality System Certificate UNI EN ISO 9001:2015 and UNI EN ISO 13485:2021

**\*\*HIGH RANGE ENT UNIT\*\***

**ENT UNIT Mod. OTOCOMPACT PROFESSIONAL**



**UNIQUE FEATURES:**

- **COLOR TOUCH SCREEN 7"**  
**INSTRUMENTS TABLET on ARTICULATED ARM with OPTICAL SENSORS**
- **DUAL CONTROL SYSTEM** – WIRELESS system from touch screen for the combined 3 or 4 motors patient chair's movements plus the recall of 3 memories and 0 position (resting position)
- **AMORTIZED GUIDES FOR DRAWERS**
- **COLUMN –MADE DRAWERS with :**
  - 1 instruments drawer with two metal plates
  - 1 pull-out shelf for tampon's or depressors holders
  - 1 drawer with letter-box opening for used instruments
  - 1 compartment for waste bin
- **MOBILE ON WHEELS**
- **ONLY CONNECTION TO POWER SUPPLY NEEDED**

**THE UNIT IS PROVIDED WITH THE FOLLOWING INSTRUMENTS (Included in the standard version of the unit):**

- **Working Top** in Corian
- **Drawers Combination mod. "D"** - Nr. 1 germicide compartment (UV lamp) + nr. 1 drawer mod.E1 + nr.1 drawer mod. E2 + kit of 4 metal trays – frontal parts EPOXI PAINTED in colour at your choice among 20 nuances – HANDLES colour in accordance with structure colour.
- Power Suction System complete with **Membrane Pump** with capacity up **to 50 lt/min**
- Multi use **canister with 2 lt. capacity**
- Set of **6 stainless steel cannulas** (Frazier/Rosen/Novak) for suction tube
- **Antimicrobial filter**

**MEDI-CARE SOLUTIONS S.R.L**

SEDE LEGALE: Via Della Zecca N° 1 - 40121 Bologna (BO) Italy;  
SEDE OPERATIVA: Via Pietro Nenni 3 - 40026 Imola (BO)- Italy; Tel. ++39 0542 642046 Fax ++39 0542 642355

WEBSITE: [www.euroclinic.it](http://www.euroclinic.it) - E-MAIL: [info@euroclinic.it](mailto:info@euroclinic.it)

Capitale Sociale: € 50.000,00 i.v. - Iscrizione N° 03390661209 al Registro Imprese Bologna - P.I. e C.F. 03390661209  
R.E.A. N° 515493 - VAT 03390661209 - Registro AEE N° iscrizione IT5060000008925- N° MECC. BO056722

Azienda con Sistema di qualità certificato UNI EN ISO 9001:2015 and UNI EN ISO 13485:2021  
Company with Quality System Certificate UNI EN ISO 9001:2015 and UNI EN ISO 13485:2021

- **Auricular-washing syringe** Microprocessor-controlled heating element set at 37° C
- **Compressed Air System** for medicaments
- **Insufflation system** (Nr. 2 Politzer olives included)
- **Larynx Mirror Warmer**
- N.2 Head-lamp fixed supports
- **Nr. 3 LED LIGHT SOURCES** 5.500°K – 200 Lumen – as follows
  - **Nr. 1 LED LIGHT SOURCE WITH HANDPIECE** direct connection to endoscopes
  - **Nr. 2 LED LIGHT SOURCES with outlets** for connection for F.O. cable and headlight
- **Nr. 1 FIBER OPTIC CABLE** complete with adaptors l=180,00 cm/diam. 3,5 mm
- **Nr. 3 ENDOSCOPES HOLDERS** integrated in the unit's structure
- **Nr. 1 HEADLIGHT with FIBER OPTIC CABLE by FAROMED**

### OPTIONAL APPLICATIONS:

<b><u>SUCTION APPLICATIONS</u></b> to be selected between		
21104097	Automatic discharge System (as replacement of the 2 lt. multiuse jar already included)	
21104098	Automatic rinsing system for suction tubes	
<b><u>STRUCTURES AND WORKING TOP APPLICATION</u></b> to be selected between		
21104105/B	<b>N.8 ENDOSCOPE SUPPORTS – 4 white holders for clean + 4 black holders for dirty</b> (N. 6 type short for rigid endoscopes and N.2 type long for flexible) - as replacement of the nr. 3 supports already included in the standard version)	
21104105/A	Application of <b>2 heated endoscope supports</b>	
21104200	<b>Superior modular desk for instruments</b> provided with 12 inox plates (autoclavable) and a transparent protection cover	
21104130	<b>Warming application</b> for superior modular desk	
21104154+ 21104048	<b>Pole support</b> for microscope complete with articulated arm for monitor	
<b><u>CAMERA APPLICATIONS</u></b> to be selected between		
21104121 25502029 56583228 25502012 21104120	Application of <b>HD Camera ED1400</b> already complete with EDM_videocapture Software and PC system NUC I7 with HD monitor 24" and wireless mouse/keyboard + camera keyboard + receiver and wireless foot control for taking snapshot	
21104116+ 21104121+ 21102012	Application of <b>ED420 (1/3CCD) wired camera</b> already complete with EDM_videocapture Software and PC system NUC I7 with HD monitor 24" and wireless mouse/keyboard	
<b><u>MICROSCOPE APPLICATIONS</u></b> to be selected between		
56596001	<b>Zeiss</b> microscope mod. OPMI PICO to be mounted on the unit's pole support;	
56596030	<b>LED</b> application for Zeiss microscope	
56593052	Zeiss <b>endoport</b> , for connecting an external camera	
56596050	<b>Kaps</b> microscope mod. SOM22 with <b>LED light</b> – made in Germany	

#### MEDI-CARE SOLUTIONS S.R.L

SEDE LEGALE: Via Della Zecca N° 1 - 40121 Bologna (BO) Italy;  
 SEDE OPERATIVA: Via Pietro Nenni 3 - 40026 Imola (BO)- Italy; Tel. ++39 0542 642046 Fax ++39 0542 642355  
 WEBSITE: [www.euroclinic.it](http://www.euroclinic.it) - E-MAIL: [info@euroclinic.it](mailto:info@euroclinic.it)  
 Capitale Sociale: € 50.000,00 i.v. - Iscrizione N° 03390661209 al Registro Imprese Bologna - P.I. e C.F. 03390661209  
 R.E.A. N° 515493 - VAT 03390661209 - Registro AEE N° iscrizione IT5060000008925- N° MECC. B0056722

Azienda con Sistema di qualità certificato UNI EN ISO 9001:2015 and UNI EN ISO 13485:2021  
 Company with Quality System Certificate UNI EN ISO 9001:2015 and UNI EN ISO 13485:2021

56596010	<b>Kaps beam splitter</b> for connecting an external camera	
56596091	<b>Labomed</b> microscope mod. <b>PRIMA</b> (LED light) mounted on unit	
56596093	<b>Labomed beam splitter and Endo Adapter</b>	
56596041	Professional examination <b>ZUMAX microscope model OMS2350 with LED light</b> – made in China	
56596043	<b>Zumax beam splitter and camera adapter</b>	
	<b>FLEXIBLE &amp; RIGID SCOPES – TO BE QUOTED ON DEMAND</b>	

Tensione di alimentazione/Power supply tension/Tension d'alimentation électrique	220/240 V (110/115 VAC)
Frequenza /Frequency/Fréquence	50/60 Hz
Potenza assorbita (configurazione MAX)/Absorbed power (MAX configuration) /Puissance absorbée (MAX configuration)	1200 VA
Peso/Weight/Poids	120 Kg
Numero massimo di strumenti/Maimum instruments nr./Nr. maximum des instruments	4
Portata aria insufflatore/Insufflator air capacity/Capacité d'air insufflateur	26 l/m (variazione fino a 250 Kpa) (variance until 250 Kpa) (variance jusqu'à 250 Kpa)
Aspirazione motore a secco/Oil free suction motor/Aspiration moteur à sec	-86 KPa (-650 mm Hg,50L/min)
Aspirazione motore ad olio/Suction with oil motor/Aspiration avec moteur à huile	-86 KPa (-650 mm Hg,50L/min)
Fusibili alimentazione/Fuses power supply/Fusibles alimentation électrique	F1, F2 = 6,3A T
Fusibile Presa esterna /Fuse external Plug/Fusibile de la prise de courant externe	F3 =4A T

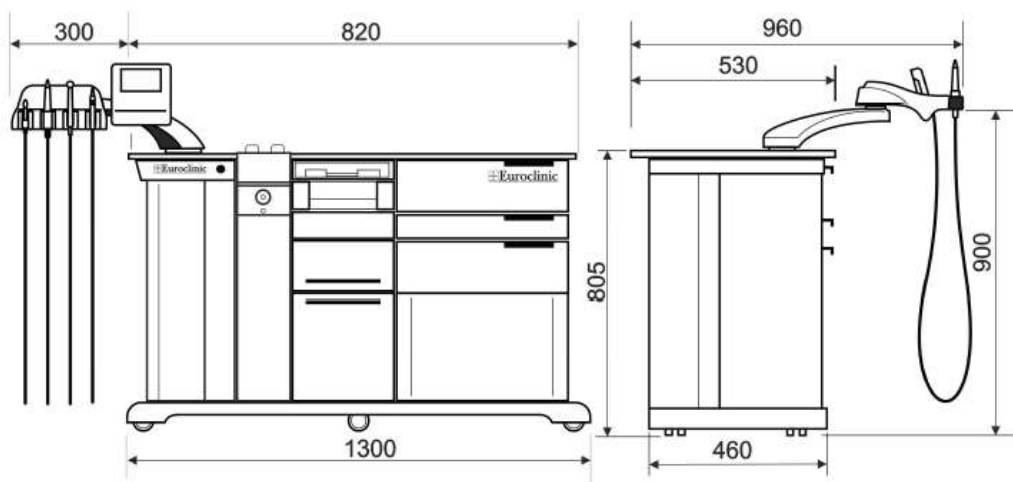

### MEDI-CARE SOLUTIONS S.R.L

SEDE LEGALE: Via Della Zecca N° 1 - 40121 Bologna (BO) Italy;  
 SEDE OPERATIVA: Via Pietro Nenni 3 - 40026 Imola (BO)- Italy; Tel. ++39 0542 642046 Fax ++39 0542 642355  
 WEBSITE: [www.euroclinic.it](http://www.euroclinic.it) - E-MAIL: [info@euroclinic.it](mailto:info@euroclinic.it)  
 Capitale Sociale: € 50.000,00 i.v. - Iscrizione N° 03390661209 al Registro Imprese Bologna - P.I. e C.F. 03390661209  
 R.E.A. N° 515493 - VAT 03390661209 - Registro AEE N° iscrizione IT5060000008925- N° MECC. BO056722

Azienda con Sistema di qualità certificato UNI EN ISO 9001:2015 and UNI EN ISO 13485:2021  
 Company with Quality System Certificate UNI EN ISO 9001:2015 and UNI EN ISO 13485:2021

**ENT UNIT Mod. OTOCOMPACT STEEL**



**UNIQUE FEATURES:**

- **COLOR TOUCH SCREEN 7"**
- **INSTRUMENTS TABLET on ARTICULATED ARM with OPTICAL SENSORS**
- **DUAL CONTROL SYSTEM** – WIRELESS system from touch screen for the combined 3-4 motors patient chair's movements plus the recall of 3 memories and 0 position (resting position)
- **AMORTIZED GUIDES FOR DRAWERS**
- **1 WASTE COMPARTMENT UNDER THE MAIN DRAWERS COMBINATION**
- **MOBILE ON WHEELS**
- **ONLY CONNECTION TO POWER SUPPLY NEEDED**

**THE UNIT IS PROVIDED WITH THE FOLLOWING INSTRUMENTS (Included in the standard version of the unit):**

- **Working Top**\_in Corian
- **Drawers Combination Mod. "D"** Nr. 1 germicide compartment (UV lamp) + nr. 2 drawer mod.E1 + nr.1 drawer mod. E2 + kit of 4 metal trays – frontal parts EPOXI PAINTED in colour at your choice among 20 nuances – HANDLES colour in accordance with structure colour.
- Power Suction System complete with **Membrane Pump** with capacity up **to 50 lt/min**
- Multi use **canister with 2 lt. capacity**
- **Antimicrobial filter**
- **Auricular-washing syringe** Microprocessor-controlled heating element set at 37° C.
- **Compressed Air System** for medicaments
- Application of **insufflation canula** on medicament syringe, Politzer olives included
- **Larynx Mirror Warmer**
- Nr. 2 Head -lamp fixed supports
- **Nr. 2 LED LIGHT SOURCES** 5.500°K – 200 Lumen – as follows

**MEDI-CARE SOLUTIONS S.R.L**

SEDE LEGALE: Via Della Zecca N° 1 - 40121 Bologna (BO) Italy;  
SEDE OPERATIVA: Via Pietro Nenni 3 - 40026 Imola (BO)- Italy; Tel. ++39 0542 642046 Fax ++39 0542 642355  
WEBSITE: [www.euroclinic.it](http://www.euroclinic.it) - E-MAIL: [info@euroclinic.it](mailto:info@euroclinic.it)  
Capitale Sociale: € 50.000,00 i.v. - Iscrizione N° 03390661209 al Registro Imprese Bologna - P.I. e C.F. 03390661209  
R.E.A. N° 515493 - VAT 03390661209 - Registro AEE N° iscrizione IT506000008925 - N° MECC. B0056722

Azienda con Sistema di qualità certificato UNI EN ISO 9001:2015 and UNI EN ISO 13485:2021  
Company with Quality System Certificate UNI EN ISO 9001:2015 and UNI EN ISO 13485:2021

- **Nr. 1 LED LIGHT SOURCE WITH HANDPIECE** direct connection to endoscopes
- **Nr. 1 LED LIGHT SOURCES with SINGLE OUTLET** for connection of F.O. Cable
- **Nr. 1 FIBER OPTIC CABLE** complete with adaptors l=180,00 cm/diam. 3,5 mm
- **Nr. 2 Holders for Endoscopes** (external with 2 tubes)

## **OPTIONAL APPLICATIONS :**

<b>SUCTION APPLICATIONS</b> to be selected between		
21104097	Automatic discharge System (as replacement of the 2 lt. multiuse jar already included)	
21104098	Automatic rinsing system for suction tubes	
<b>STRUCTURES AND WORKING TOP APPLICATION</b> to be selected between		
21104092	<b>Application of LED LIGHT SOURCE with double exit 5.500°k – 200 L</b> (as replacement of the single exit one already included)	
21104127	<b>Superior modular desk for instruments</b> provided with 9 inox plates (autoclavable) and a transparent protection cover	
21104130	<b>Warming application</b> for superior modular desk	
21104154+ 21104048	<b>Pole support</b> for microscope complete with articulated arm for monitor	
<b>CAMERA APPLICATIONS</b> to be selected between		
21104121 25502029 56583228 25502012 21104120	Application of <b>HD Camera ED1400</b> already complete with EDM_videocapture Software and PC system NUC I7 with HD monitor 24" and wireless mouse/keyboard + camera keyboard + receiver and wireless foot control for taking snapshot	
21104116+ 21104121+ 21102012	Application of <b>ED420 (1/3CCD) wired camera</b> already complete with EDM_videocapture Software and PC system NUC I7 with HD monitor 24" and wireless mouse/keyboard	
<b>MICROSCOPE APPLICATIONS</b> to be selected between		
56596050	<b>Kaps</b> microscope mod. SOM22 with <b>LED light</b> – made in Germany	
56596010	<b>Kaps beam splitter</b> for connecting an external camera	
<b>PROPOSAL HEADLIGHT &amp; FLEXIBLE SCOPES</b>		
56583055	F.O. HEADLIGHT with fiber optic cable	
<b>FLEXIBLE &amp; RIGID SCOPES – TO BE QUOTED ON DEMAND</b>		

### **MEDI-CARE SOLUTIONS S.R.L**

SEDE LEGALE: Via Della Zecca N° 1 - 40121 Bologna (BO) Italy;  
 SEDE OPERATIVA: Via Pietro Nenni 3 - 40026 Imola (BO)- Italy; Tel. ++39 0542 642046 Fax ++39 0542 642355  
 WEBSITE: [www.euroclinic.it](http://www.euroclinic.it) - E-MAIL: [info@euroclinic.it](mailto:info@euroclinic.it)  
 Capitale Sociale: € 50.000,00 i.v. - Iscrizione N° 03390661209 al Registro Imprese Bologna - P.I. e C.F. 03390661209  
 R.E.A. N° 515493 - VAT 03390661209 - Registro AEE N° iscrizione IT5060000008925- N° MECC. BO056722

**Azienda con Sistema di qualità certificato UNI EN ISO 9001:2015 and UNI EN ISO 13485:2021**  
**Company with Quality System Certificate UNI EN ISO 9001:2015 and UNI EN ISO 13485:2021**

Tensione di alimentazione/Power supply tension/Tension d'alimentation électrique	230 V +/- 10% optional 110V +/-10%
Frequenza/Frequency/Fréquence	50/60 Hz
Potenza assorbita (configurazione MAX)/Absorbed power (MAX configuration)/Puissance absorbée (MAX configuration)	1200 VA
Peso/Weight/Poids	100 Kg
Numero massimo di strumenti/Maimum instruments nr./Nr.maximum des instruments	4
Portata aria insufflatore/Insufflator ait capacity/Capacité d'air insufflateur	26 l/m (Variazione fino a 250 Kpa)
Portata siringa lavaggi/Washing stringe capacity/Capacité seringue lavages	350/400 cc/min (a 2,2 Bar)
Aspirazione (motore a secco)/Nominal suction ( motor)/Aspiration nominale (moteur )	-86 KPa (-650 mmHg) 50 L/min con variazione infinita
Vaso segreti	1Lt (optional 2 Lt) pluriuso o monouso
Fusibili alimentazione/power supply fuses/Fusibles alimentation électrique	F1, F2 = 6,3A T

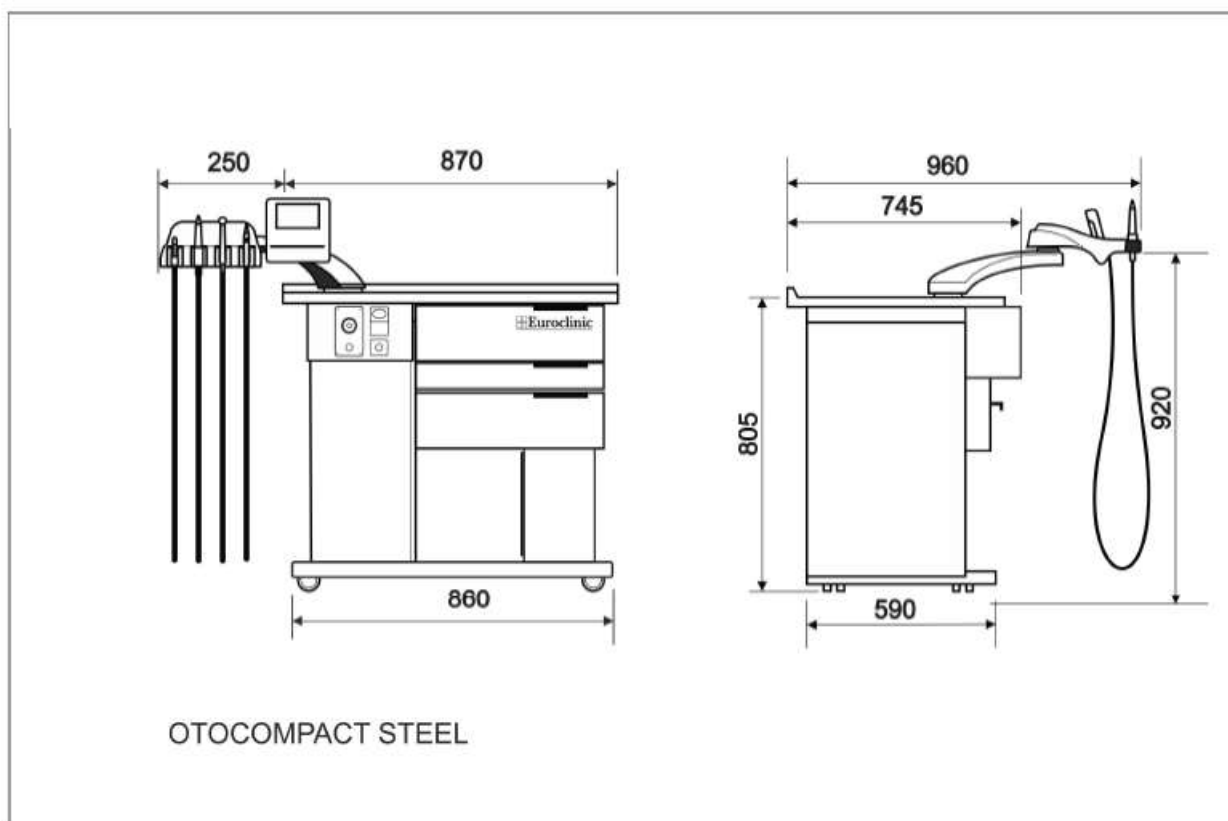

### MEDI-CARE SOLUTIONS S.R.L

SEDE LEGALE: Via Della Zecca N° 1 - 40121 Bologna (BO) Italy;

SEDE OPERATIVA: Via Pietro Nenni 3 - 40026 Imola (BO)- Italy; Tel. ++39 0542 642046 Fax ++39 0542 642355

WEBSITE: [www.euroclinic.it](http://www.euroclinic.it) - E-MAIL: [info@euroclinic.it](mailto:info@euroclinic.it)

Capitale Sociale: € 50.000,00 i.v. - Iscrizione N° 03390661209 al Registro Imprese Bologna - P.I. e C.F. 03390661209  
R.E.A. N° 515493 - VAT 03390661209 - Registro AEE N° iscrizione IT5060000008925- N° MECC. BO056722

Azienda con Sistema di qualità certificato UNI EN ISO 9001:2015 and UNI EN ISO 13485:2021  
Company with Quality System Certificate UNI EN ISO 9001:2015 and UNI EN ISO 13485:2021

**\*\*BASIC RANGE ENT UNIT – MODULAR \*\***

**ENT UNIT Mod. OTOCOMPACT PLUS**



**UNIQUE FEATURES:**

- **AMORTIZED GUIDES FOR DRAWERS**
- **MOBILE ON WHEELS**
- **ONLY CONNECTION TO POWER SUPPLY NEEDED**
- **MANOMETER AND VACUUMETER ANALOGICAL**

**THE UNIT IS PROVIDED WITH THE FOLLOWING INSTRUMENTS:**

- **Sturdy steel casing / Durable material** provided with **4 heavy-duty castors** necessary for its mobility and easy cleaning of the examination room. Service box with easy lateral access.
- **Desk working top in LAMINATED WOOD** – Easy to clean
- **Drawers Combination mod. “D”** - Nr. 1 germicide compartment (UV lamp) + nr. 1 drawer mod.E1 + nr.1 drawer mod. E2 + kit of 4 metal trays – frontal parts EPOXI PAINTED in colour at your choice among 20 nuances – HANDLES colour in accordance with structure colour.
- Power Suction System complete with **Membrane Pump** with capacity up **to 50 lt/min**
- Multi use **canister with 2 lt. capacity**
- **Antimicrobial filter**
- **Auricular-washing syringe** Microprocessor-controlled heating element set at 37° C.
- **Larynx Mirror Warmer**
- Nr. 2 Head -lamp fixed supports
- **Led light source with 1 channel with** with bright LED bulb 5.500°K 200 Lumen (50.000 hours life bulb) – STORZ connectors (or any connector if requested) + **n.1 Fiber optic cord/light carrier for endoscope + adaptors Ø 3.5 mm / L.1,800 mm**

**MEDI-CARE SOLUTIONS S.R.L**

SEDE LEGALE: Via Della Zecca N° 1 - 40121 Bologna (BO) Italy;  
SEDE OPERATIVA: Via Pietro Nenni 3 - 40026 Imola (BO)- Italy; Tel. ++39 0542 642046 Fax ++39 0542 642355  
WEBSITE: [www.euroclinic.it](http://www.euroclinic.it) - E-MAIL: [info@euroclinic.it](mailto:info@euroclinic.it)  
Capitale Sociale: € 50.000,00 i.v. - Iscrizione N° 03390661209 al Registro Imprese Bologna - P.I. e C.F. 03390661209  
R.E.A. N° 515493 - VAT 03390661209 - Registro AEE N° iscrizione IT5060000008925- N° MECC. BO056722

Azienda con Sistema di qualità certificato UNI EN ISO 9001:2015 and UNI EN ISO 13485:2021  
Company with Quality System Certificate UNI EN ISO 9001:2015 and UNI EN ISO 13485:2021



- **N.3 HOLDERS FOR ENDOSCOPES** which can be filled with disinfectant for sterilization of endoscope – N. 2 storage quivers for rigid endoscopes (dirty short /closed) + N. 1 storage quiver for flexible nasopharyngoscope



## OPTIONAL APPLICATIONS

<b>SUCTION APPLICATIONS</b> to be selected between		
21104097	Automatic discharge System (as replacement of the 2 lt. multiuse jar already included)	
<b>STRUCTURES AND WORKING TOP APPLICATION</b> to be selected between		
21104127	<b>Superior modular desk for instruments</b> provided with 9 inox plates (autoclavable) and a transparent protection cover	
21104154+ 21104048	<b>Pole support</b> for microscope complete with articulated arm for monitor	
21104180	<b>Compressed air system for medicaments</b> provided with: <ul style="list-style-type: none"> <li>- Air syringe group for spray olives;</li> <li>- Nr. 2 straight atomizers: 1 for powder spray and 1 for liquid spray;</li> <li>- Nr. 2 olives for medicaments;</li> <li>- Nr. 1 insufflation canula application to medicament gun</li> </ul>	
<b>INTEGRATED LED LIGHT SOURCES</b>		
21104210-21104211	<b>LED light source</b> , with temperature of 5500° Kelvin and 200 Lumen – with <b>hand-piece</b> for direct connection to endoscopes and laryngoscope	
21104210-21104092	<b>LED light source</b> 5.500° K – 200 L with <b>double</b> output for fibre optic cable	
21104210-21104128	<b>LED light source</b> 5.500° K – 200 L with <b>three</b> output for fibre optic cable	
21003418-20009176	<b>Camera support</b> placed closed to the light module	
21104039/A	<b>8 Endoscope holders</b> integrated in the column	
21104105/B	<b>Application of n.2 heated</b> endoscopes (1 short for rigid/1 long for	

### MEDI-CARE SOLUTIONS S.R.L

SEDE LEGALE: Via Della Zecca N° 1 - 40121 Bologna (BO) Italy;  
 SEDE OPERATIVA: Via Pietro Nenni 3 - 40026 Imola (BO)- Italy; Tel. ++39 0542 642046 Fax ++39 0542 642355  
 WEBSITE: [www.euroclinic.it](http://www.euroclinic.it) - E-MAIL: [info@euroclinic.it](mailto:info@euroclinic.it)  
 Capitale Sociale: € 50.000,00 i.v. - Iscrizione N° 03390661209 al Registro Imprese Bologna - P.I. e C.F. 03390661209  
 R.E.A. N° 515493 - VAT 03390661209 - Registro AEE N° iscrizione IT5060000008925- N° MECC. B0056722

Azienda con Sistema di qualità certificato UNI EN ISO 9001:2015 and UNI EN ISO 13485:2021  
 Company with Quality System Certificate UNI EN ISO 9001:2015 and UNI EN ISO 13485:2021

	flexible)	
<b>CAMERA APPLICATIONS</b> to be selected between		
21104121 25502029 56583228 25502012 21104120	Application of <b>HD Camera ED1400</b> already complete with EDM_videocapture Software and PC system NUC I7 with HD monitor 24" and wireless mouse/keyboard + camera keyboard + receiver and wireless foot control for taking snapshot	
21104116+ 21104121+ 21102012	Application of <b>ED420 (1/3CCD) wired camera</b> already complete with EDM_videocapture Software and PC system NUC I7 with HD monitor 24" and wireless mouse/keyboard	
<b>PROPOSAL HEADLIGHT &amp; FLEXIBLE SCOPES</b>		
56583055	F.O. HEADLIGHT with fiber optic cable	
	<b>FLEXIBLE &amp; RIGID SCOPES – TO BE QUOTED ON DEMAND</b>	

## ADDITIONAL DRAWER'S MODULE

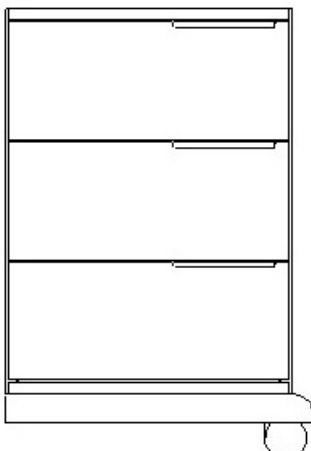
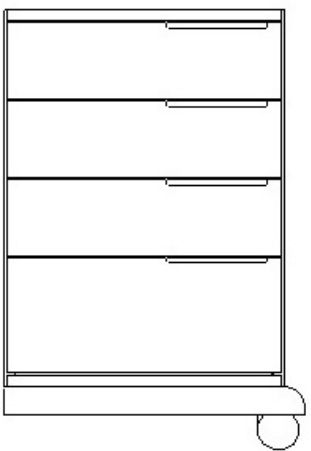
<h3>00XPLUS3</h3> 	<p>Unit with 3 drawers type D3</p> <p>Dimension in mm</p> <table border="1"> <tr><td>Height</td><td>820</td></tr> <tr><td>Length</td><td>500</td></tr> <tr><td>Depth</td><td>540</td></tr> </table>	Height	820	Length	500	Depth	540	<h3>00XPLUS4</h3> 	<p>Unit with 4 drawers 3 type D2 + 1 type D3</p> <p>Dimension in mm</p> <table border="1"> <tr><td>Height</td><td>820</td></tr> <tr><td>Length</td><td>500</td></tr> <tr><td>Depth</td><td>540</td></tr> </table>	Height	820	Length	500	Depth	540
Height	820														
Length	500														
Depth	540														
Height	820														
Length	500														
Depth	540														

### MEDI-CARE SOLUTIONS S.R.L

SEDE LEGALE: Via Della Zecca N° 1 - 40121 Bologna (BO) Italy;  
 SEDE OPERATIVA: Via Pietro Nenni 3 - 40026 Imola (BO)- Italy; Tel. ++39 0542 642046 Fax ++39 0542 642355  
 WEBSITE: [www.euroclinic.it](http://www.euroclinic.it) - E-MAIL: [info@euroclinic.it](mailto:info@euroclinic.it)  
 Capitale Sociale: € 50.000,00 i.v. - Iscrizione N° 03390661209 al Registro Imprese Bologna - P.I. e C.F. 03390661209  
 R.E.A. N° 515493 - VAT 03390661209 - Registro AEE N° iscrizione IT5060000008925- N° MECC. BO056722

**Azienda con Sistema di qualità certificato UNI EN ISO 9001:2015 and UNI EN ISO 13485:2021**  
**Company with Quality System Certificate UNI EN ISO 9001:2015 and UNI EN ISO 13485:2021**

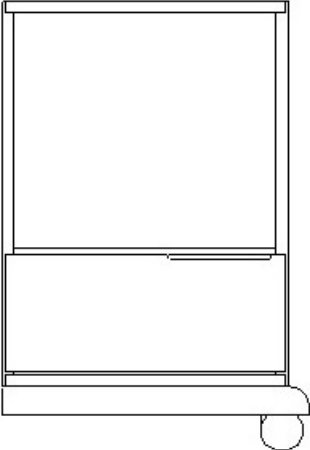
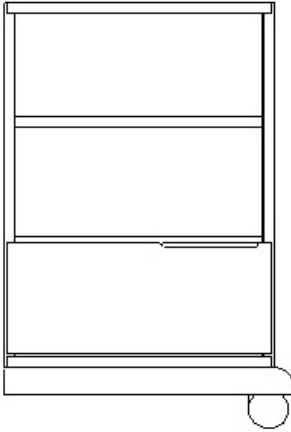
<p><b>00XPLUSP</b></p> 	<p>Unit where housing sterilizer or for stand-alone equipment, <b>(model of stand-alone device to be defined at the moment of the order)</b></p> <p>Dimension in mm</p> <table border="1"> <tr> <td>Height</td> <td>820</td> </tr> <tr> <td>Length</td> <td>500</td> </tr> <tr> <td>Depth</td> <td>540</td> </tr> </table>	Height	820	Length	500	Depth	540	<p><b>00XPLUSP2</b></p> 	<p>Unit where housing sterilizer or for stand-alone equipment , with 2 open compartments <b>(model of stand-alone device to be defined at the moment of the order)</b></p> <p>Dimension in mm</p> <table border="1"> <tr> <td>Height</td> <td>820</td> </tr> <tr> <td>Length</td> <td>500</td> </tr> <tr> <td>Depth</td> <td>540</td> </tr> </table>	Height	820	Length	500	Depth	540
Height	820														
Length	500														
Depth	540														
Height	820														
Length	500														
Depth	540														

**\*\*BASIC RANGE ENT UNIT \*\***

**ENT UNIT Mod. OTOPLUS**



**FEATURES:**

- **BASIC INSTRUMENTS TABLET on ARTICULATED ARM**
- **MOBILE ON WHEELS**
- **ONLY CONNECTION TO POWER SUPPLY**

**THE UNIT IS PROVIDED WITH THE FOLLOWING INSTRUMENTS (Included in the standard version of the unit):**

- **Working top** in white laminated wood

**MEDI-CARE SOLUTIONS S.R.L**

SEDE LEGALE: Via Della Zecca N° 1 - 40121 Bologna (BO) Italy;  
SEDE OPERATIVA: Via Pietro Nenni 3 - 40026 Imola (BO)- Italy; Tel. ++39 0542 642046 Fax ++39 0542 642355  
WEBSITE: [www.euroclinic.it](http://www.euroclinic.it) - E-MAIL: [info@euroclinic.it](mailto:info@euroclinic.it)  
Capitale Sociale: € 50.000,00 i.v. - Iscrizione N° 03390661209 al Registro Imprese Bologna - P.I. e C.F. 03390661209  
R.E.A. N° 515493 - VAT 03390661209 - Registro AEE N° iscrizione IT5060000008925- N° MECC. BO056722

Azienda con Sistema di qualità certificato UNI EN ISO 9001:2015 and UNI EN ISO 13485:2021  
Company with Quality System Certificate UNI EN ISO 9001:2015 and UNI EN ISO 13485:2021

- **Drawers Combination Mod. S5** composed of N. 2 T1 drawer + N. 1 germicide compartment (UV lamp) + N. 1 T2 drawer+ Kit of 4 metal trays included with handles and decors painted in colour at your choice among 20 nuances
- **Suction System** complete with oil less pump with capacity up to 34 lt./min.
- **Antimicrobial filter**
- Multi use canister with 1 lt. capacity with overflow valve
- **Auricular-washing syringe** Microprocessor-controlled heating element set at 37° C.
- **Insufflation system**
- **Larynx Mirror Warmer**
- **Nr. 1 Head -lamp fixed support**

### **OPTIONAL APPLICATIONS :**

<b>SUCTION APPLICATIONS</b> to be selected between		
21104123	Suction pump with 50 lt./min – diaphragm pump (as alternative to the 40 lt. standard)	
21104094/A	Suction pump with 70 lt./min – oil pump (as alternative to the 40 lt. standard)	
<b><u>UNIT'S ACCESSORIES</u></b>		
21100460	<b>NR. 2 FLIP UP DRAWERS</b> to be used as waste bin, under the drawing combination	
21104061	<b>KIT OF 6 STAINLESS STEEL SUCTION CANULAS</b>	
21100422_9003	<b>Fixed holders for endoscope</b> (external) nr. 2 supports, one for rigid and one for flexible scopes	
21104180	<b>Kit for medicaments</b> composed of: nr. 1 gun in stainless steel + nr. 2 bottles for medicaments complete with autoclavable atomizers (1 for powder and 1 for liquid medicaments)	
<b>LIGHT SOURCE APPLICATIONS – Stand alone, to be placed on the unit's working top</b>		
25502015	LED light source mod. ED1100 – <b>single</b> outlet for fibre optic cable – temperature LED 5.500°K – 200 L. Light intensity manually adjustable	
25502016	LED light source mod. ED1102 – <b>double</b> outlet for fibre optic cable – temperature LED 5.500°K – 200 L. Light intensity manually adjustable	
56500122/A	Fibre optic cable length 1800 mm / diameter 3,5 mm	

#### **MEDI-CARE SOLUTIONS S.R.L**

SEDE LEGALE: Via Della Zecca N° 1 - 40121 Bologna (BO) Italy;  
 SEDE OPERATIVA: Via Pietro Nenni 3 - 40026 Imola (BO)- Italy; Tel. ++39 0542 642046 Fax ++39 0542 642355  
 WEBSITE: [www.euroclinic.it](http://www.euroclinic.it) - E-MAIL: [info@euroclinic.it](mailto:info@euroclinic.it)  
 Capitale Sociale: € 50.000,00 i.v. - Iscrizione N° 03390661209 al Registro Imprese Bologna - P.I. e C.F. 03390661209  
 R.E.A. N° 515493 - VAT 03390661209 - Registro AEE N° iscrizione IT5060000008925- N° MECC. BO056722

**Azienda con Sistema di qualità certificato UNI EN ISO 9001:2015 and UNI EN ISO 13485:2021**  
**Company with Quality System Certificate UNI EN ISO 9001:2015 and UNI EN ISO 13485:2021**

## ENT UNIT OTOPLUS

Tensione di alimentazione/Power supply tension/Tension d'alimentation électrique	220/240 V (110/115 VAC)
Frequenza /Frequency/Fréquence	50/60 Hz
Potenza assorbita (configurazione MAX) /Absorbed power (MAX configuration)/Puissance absorbée (MAX configuration)	1200 VA
Peso/Weight/Poids	120 Kg
Numero massimo di strumenti/Maimum instruments nr./Nr.maximum des instruments	4
Portata aria insufflatore/Insufflator ait capacity/Capacité d'air insufflateur	26 l/m (variazione fino a 250 Kpa ) (variance until 250 Kpa ) (variance jusqu'à 250 Kpa )
Aspirazione motore a secco/Oil free suction motor/Aspiration moteur à sec	-82 KPa (-615 mm Hg, 34L/min)
Fusibili alimentazione/Fuses power supply/Fusibles alimentation électrique	F1, F2 = 6,3A T
Fusibile Presa esterna /Fuse external Plug/Fusible de la prise de courant externe	F3 =4A T

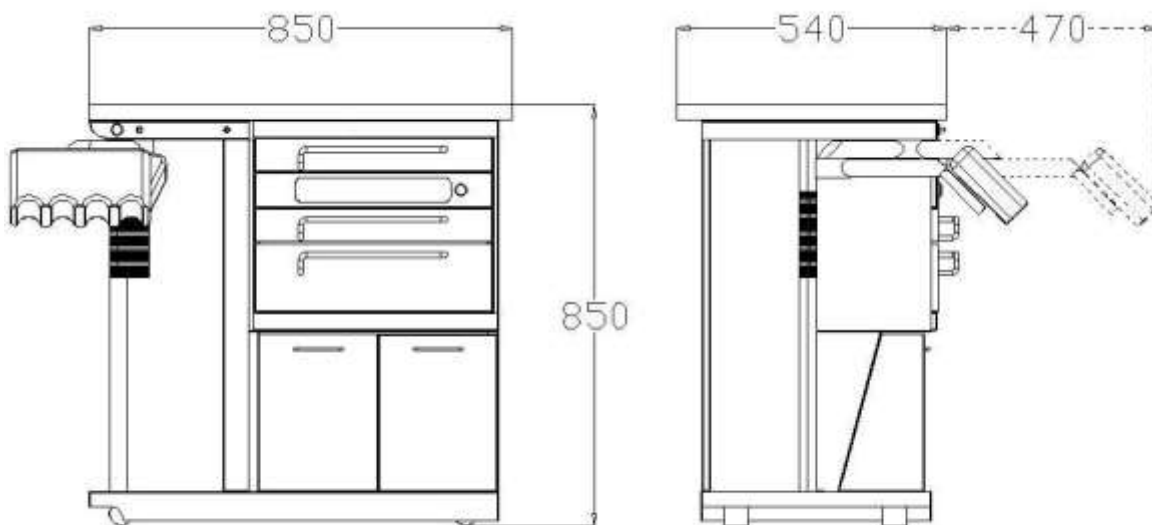

### MEDI-CARE SOLUTIONS S.R.L

SEDE LEGALE: Via Della Zecca N° 1 - 40121 Bologna (BO) Italy;  
 SEDE OPERATIVA: Via Pietro Nenni 3 - 40026 Imola (BO)- Italy; Tel. ++39 0542 642046 Fax ++39 0542 642355  
 WEBSITE: [www.euroclinic.it](http://www.euroclinic.it) - E-MAIL: [info@euroclinic.it](mailto:info@euroclinic.it)  
 Capitale Sociale: € 50.000,00 i.v. - Iscrizione N° 03390661209 al Registro Imprese Bologna - P.I. e C.F. 03390661209  
 R.E.A. N° 515493 - VAT 03390661209 - Registro AEE N° iscrizione IT5060000008925- N° MECC. BO056722

Azienda con Sistema di qualità certificato UNI EN ISO 9001:2015 and UNI EN ISO 13485:2021  
 Company with Quality System Certificate UNI EN ISO 9001:2015 and UNI EN ISO 13485:2021

## ENT CHAIR MOD. XENON EVO 5 Motors



ENT chair equipped with 4 linear motors operating independently the seat (up to **flat and Trendelenburg** position), the backrest, the UP/DOWN movement and the single leg-rest plus a 5<sup>th</sup> motor to unlock/lock rotation.

XENON EVO is characterized by a **Telescopic Column** granting a vertical lifting (**motorized lifting mechanism**) with a wider excursion between the minimum and maximum position, making the chair the best choice for examination both on adults and on children patients, always ensuring an easy access to patients.

**The adjustment of seat height is 35 cm, within a range of 54cm to max 89 cm height so that no additional seat accessories are needed for examining children.**

The maximum stability is always granted thanks to the **360° rotation** (manual) at the base level, lockable/unlockable through a dedicated button on the foot pedal that, activating an Electronic Signal, grants an easy and quick rotation, avoiding interruption during the normal working procedures of the Doctors. **Pre settled backrest position at +3°** to facilitate ENT examination.

**Control of all motorized chair's movements by WIRED foot-control (wireless optional).** All the desired positions can be quickly reached thanks to a multi-functional foot control with possibility to set 2 memories (at customer's choice) along with M0 button to recall entry/exit position.

**Comfortable thick foam padding** available in many different colors and upholstered single leg-rest, provided with folded foot-rest with reduced dimensions (14 cm) and equipped with "over-load" safety system. Stainless steel kick plate.

**Articulated head-rest mechanism (20 cm excursion – adjustable head rest)** to adjust head support in all dimensions (vertical and inclination) for a perfect adaptability to the patient's morphology.

**Armrests** of the chair are comfortably padded and these can be folded back for enabling easy sitting of overweight or handicapped patients. **Safe working load: 300 kg.**

### MEDI-CARE SOLUTIONS S.R.L

SEDE LEGALE: Via Della Zecca N° 1 - 40121 Bologna (BO) Italy;  
SEDE OPERATIVA: Via Pietro Nenni 3 - 40026 Imola (BO)- Italy; Tel. ++39 0542 642046 Fax ++39 0542 642355

WEBSITE: [www.euroclinic.it](http://www.euroclinic.it) - E-MAIL: [info@euroclinic.it](mailto:info@euroclinic.it)

Capitale Sociale: € 50.000,00 i.v. - Iscrizione N° 03390661209 al Registro Imprese Bologna - P.I. e C.F. 03390661209  
R.E.A. N° 515493 - VAT 03390661209 - Registro AEE N° iscrizione IT5060000008925- N° MECC. BO056722

Azienda con Sistema di qualità certificato UNI EN ISO 9001:2015 and UNI EN ISO 13485:2021  
Company with Quality System Certificate UNI EN ISO 9001:2015 and UNI EN ISO 13485:2021

**ENT CHAIR Mod. LYNEA EVO 4 Motors**

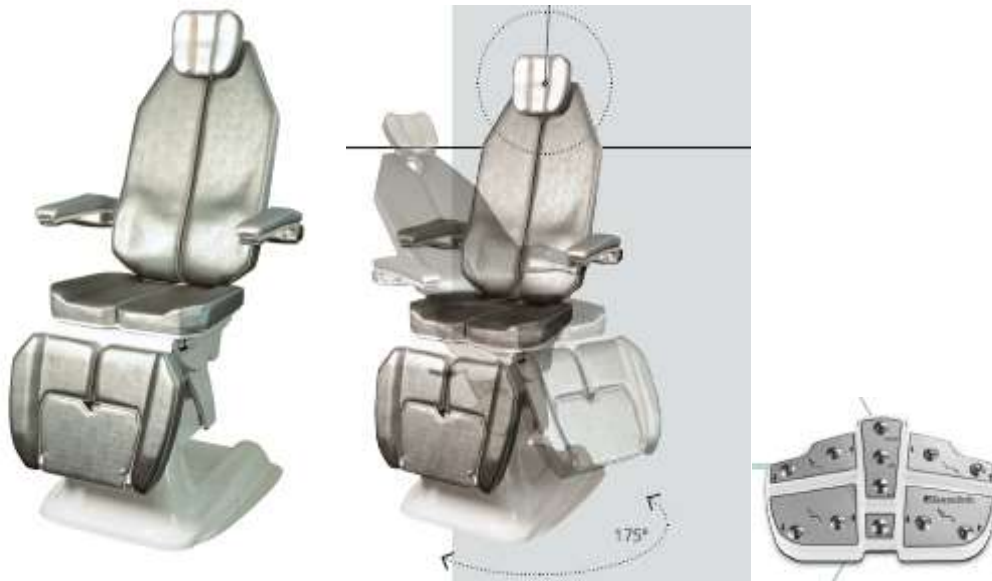

- **pillows easily removable (with magnet system)** in order to allow the replacement of each piece for repair or for the simple colour change
- **n. 4 linear motors operating independently the seat, the backrest, the legrest and up/down movement**
- IT CAN BE CONTROLLED IN WIRELESS MODE AND IN EACH MOVEMENTS ( ACTIVATION AND VISUALISATION) by DUAL CONTROL from unit's Touch Screen or by the WIRELESS PEDAL. (optional)
- solid structure in metal painted with epoxy powders (colour white ral 9006 or RAL 9003) refined with elegant covers moulded in high resistance
- -26° inclination of seat and legrest up to **Trendelenburg** position;
- Synchronous coupling of the foot support -seat movement to grant a security **fixed 90° angle** to prevent the body's patient squeezing (**safety system**)
- WIRED pedal for independent chair's movements control. it is also provided with memories: 2 memorized positions chosen by the operator , "zero" resting position + synchro position for the combined movement of legrest and backrest .
- **rotation** of 175° right and left with manual locking device.
- **single leg-rests electrically operated** and provided with foldable footrest. protected by an iron plate
- Height adjustable and detachable articulated head-rest\_on a sliding bar rollaway in the backrest cover of a state-of-the-art design (highly suitable for different heights of the patient's head)
- Pelted **armrests** to be separately **swivelled off** backwards; allowing easy entrance of the patient by the side. The arm-rests can follow chair's movement;
- The seat, backrest and legrest are pelted in high-density foam (50kg./cm3) and covered with flame retardant, highly resistant and bi-elastic, anti-microbial and anti-scratch skay in **40 different colours at choice**.

**MEDI-CARE SOLUTIONS S.R.L**

SEDE LEGALE: Via Della Zecca N° 1 - 40121 Bologna (BO) Italy;  
SEDE OPERATIVA: Via Pietro Nenni 3 - 40026 Imola (BO)- Italy; Tel. ++39 0542 642046 Fax ++39 0542 642355  
WEBSITE: [www.euroclinic.it](http://www.euroclinic.it) - E-MAIL: [info@euroclinic.it](mailto:info@euroclinic.it)  
Capitale Sociale: € 50.000,00 i.v. - Iscrizione N° 03390661209 al Registro Imprese Bologna - P.I. e C.F. 03390661209  
R.E.A. N° 515493 - VAT 03390661209 - Registro AEE N° iscrizione IT5060000008925- N° MECC. BO056722

Azienda con Sistema di qualità certificato UNI EN ISO 9001:2015 and UNI EN ISO 13485:2021  
Company with Quality System Certificate UNI EN ISO 9001:2015 and UNI EN ISO 13485:2021

## ENT CHAIR Mod. OTOCONCEPT 4 Motors

### TECHNICAL FEATURES:

- Professional **motorized** chair for ENT examination room equipped with 4 motors (smooth and silent actuators) which permit the independent movement of up/down, of seat (+5° up to – **26° Trendelenburg position**) of the backrest and of the single legrest.
- Electromotive height adjustment by pedal switch;
- **Rotation** of 175° both to the right and to the left with a position locking device. (total rotation 350°)
- Infinitely variable inclination of the backrest to the horizontal position by means of pedal (electric movement)
- Synchronous coupling of the foot support -seat movement to grant a security **fixed 90° angle** to prevent the body's patient squeezing (**safety system**)
- The chair can reach the horizontal position and be converted into a long stable couch.
- Movements are controlled by means of a **WIRED electrical foot-switch** (WIRELESS OPTIONAL) with buttons driving each single movement and for recalling 2 memories + "0" position-patient exit position synchro position for the combined movement of legrest and backrest (automatic memorization setting of the 3 desired positions by acoustic signal); By pushing a button the chair can be quickly returned into the original position after examination (Zero Position)
- The chair is provided with a single motorized leg-rest and with a foot support to be tipped up and a protection metal plate.
- **Height adjustable and detachable articulated head-rest** on a sliding bar rollaway in the backrest cover of a state-of-the-art design (highly suitable for different heights of the patient's head)
- Pelted **armrests** to be separately **swivelled off** backwards; allowing easy entrance of the patient by the side. The arm-rests can follow chair's movement;
- The seat, backrest and legrest are pelted in high-density foam (50kg./cm<sup>3</sup>) and covered with flame retardant, highly resistant and bi-elastic, anti-microbial and anti-scratch skay in **40 different colours at choice**.
- **Height: 580 mm - 900 mm**



### MEDI-CARE SOLUTIONS S.R.L

SEDE LEGALE: Via Della Zecca N° 1 - 40121 Bologna (BO) Italy;

SEDE OPERATIVA: Via Pietro Nenni 3 - 40026 Imola (BO)- Italy; Tel. ++39 0542 642046 Fax ++39 0542 642355

WEBSITE: [www.euroclinic.it](http://www.euroclinic.it) - E-MAIL: [info@euroclinic.it](mailto:info@euroclinic.it)

Capitale Sociale: € 50.000,00 i.v. - Iscrizione N° 03390661209 al Registro Imprese Bologna - P.I. e C.F. 03390661209  
R.E.A. N° 515493 - VAT 03390661209 - Registro AEE N° iscrizione IT5060000008925- N° MECC. BO056722

Azienda con Sistema di qualità certificato UNI EN ISO 9001:2015 and UNI EN ISO 13485:2021  
Company with Quality System Certificate UNI EN ISO 9001:2015 and UNI EN ISO 13485:2021

## ENT CHAIR Mod. OTOCONCEPT 3 Motors

### TECHNICAL FEATURES:

- Fully automatic /electrical professional chair for ENT examination room equipped with 3 motors (smooth and silent actuators) which permit the independent movement of up/down, of the seat (+5° up to - 26° **Trendelenburg position**) and of the backrest. The single legrest is manually adjustable via gas spring
- Electromotive height adjustment by pedal switch;
- **Rotation** of 175° both to the right and to the left with a position locking device. (total rotation 350°)
- Infinitely variable inclination of the backrest to the horizontal position by means of pedal (electric movement)
- Synchronous coupling of the foot support -seat movement to grant a security **fixed 90° angle** to prevent the body's patient squeezing (**safety system**)
- The chair can reach the horizontal position and be converted into a long stable couch.
- Movements are controlled by means of a **WIRED electrical foot-switch (WIRELESS OPTIONAL)** with buttons driving each single movement and for recalling 3 memories + "0" position-patient exit position (automatic memorization setting of the 3 desired positions by acoustic signal); and the movements can be controlled also from the unit's TOUCH SCREEN! By pushing a button the chair can be quickly returned into the original position after examination (Zero Position)
- The chair is provided with a single leg-rest (manually adjustable) and with a foot support to be tipped up and a protection metal plate.
- **Height adjustable and detachable articulated head-rest** on a sliding bar rollaway in the backrest cover of a state-of-the-art design (highly suitable for different heights of the patient's head)
- Pelted **armrests** to be separately **swivelled off** backwards; allowing easy entrance of the patient by the side. The arm-rests can follow chair's movement;
- The seat, backrest and legrest are pelted in high-density foam (50kg./cm<sup>3</sup>) and covered with flame retardant, highly resistant and bi-elastic, anti-microbial and anti-scratch skay in **40 different colours at choice.**
- **Height: 580 mm - 900 mm**



### MEDI-CARE SOLUTIONS S.R.L

SEDE LEGALE: Via Della Zecca N° 1 - 40121 Bologna (BO) Italy;  
SEDE OPERATIVA: Via Pietro Nenni 3 - 40026 Imola (BO) - Italy; Tel. ++39 0542 642046 Fax ++39 0542 642355  
WEBSITE: [www.euroclinic.it](http://www.euroclinic.it) - E-MAIL: [info@euroclinic.it](mailto:info@euroclinic.it)  
Capitale Sociale: € 50.000,00 i.v. - Iscrizione N° 03390661209 al Registro Imprese Bologna - P.I. e C.F. 03390661209  
R.E.A. N° 515493 - VAT 03390661209 - Registro AEE N° iscrizione IT5060000008925- N° MECC. BO056722

Azienda con Sistema di qualità certificato UNI EN ISO 9001:2015 and UNI EN ISO 13485:2021  
Company with Quality System Certificate UNI EN ISO 9001:2015 and UNI EN ISO 13485:2021

## OPTIONAL ACCESSORIES FOR HIGH RANGE CHAIRS

<p>22200203 22200099 22200095</p>	<p>WIRELESS FOOT-CONTROL FOR XENON EVO CHAIR WIRELESS FOOT-CONTROL FOR 4 MOTORS CHAIR <u>with</u> SYNCRO button WIRELESS FOOT CONTROL FOR 3 MOTORS CHAIR</p>  <p><b>NOTE: AS ALTERNATIVE TO THE WIRED ONE ALREADY INCLUDED IN THE CHAIR</b></p>	
<p>22200210</p>	<p><b>WIRELESS HAND CONTROL ***NEW***</b></p>  <p><b>NOTE: AS ALTERNATIVE TO THE WIRED ONE ALREADY INCLUDED IN THE CHAIR</b></p>	
<p>22200128</p>	<p>KIT APPLICATION FOR WHEELS</p>	

### MEDI-CARE SOLUTIONS S.R.L

SEDE LEGALE: Via Della Zecca N° 1 - 40121 Bologna (BO) Italy;  
SEDE OPERATIVA: Via Pietro Nenni 3 - 40026 Imola (BO)- Italy; Tel. ++39 0542 642046 Fax ++39 0542 642355  
WEBSITE: [www.euroclinic.it](http://www.euroclinic.it) - E-MAIL: [info@euroclinic.it](mailto:info@euroclinic.it)  
Capitale Sociale: € 50.000,00 i.v. - Iscrizione N° 03390661209 al Registro Imprese Bologna - P.I. e C.F. 03390661209  
R.E.A. N° 515493 - VAT 03390661209 - Registro AEE N° iscrizione IT5060000008925- N° MECC. BO056722

Azienda con Sistema di qualità certificato UNI EN ISO 9001:2015 and UNI EN ISO 13485:2021  
Company with Quality System Certificate UNI EN ISO 9001:2015 and UNI EN ISO 13485:2021

## PATIENT'S CHAIR Mod. OTOPEX 2 motors

**2-Motors ENT patient chair** with a solid construction painted in epossidic powders and with wide and comfortable seat-legrest and backrest pelted in high-density foam (50kg./cm<sup>3</sup>) and covered with flame retardant, highly resistant and bi-elastic, anti-microbial and anti-scratch skai in 40 different colours at choice.

### TECHNICAL FEATURES:

- ✓ Fully electrical lifting movement and synchronized backrest-legrest drive (smooth and silent actuators)
- ✓ Movements are controlled by means of a multi-function foot control with a home position switch (pedal with joystick and 2 buttons).
- ✓ Backrest excursion ranges from 80° to 190° synchronised with the legrest (bed position)
- ✓ The chair can rotate 90° left and right and it is equipped with a position locking device.
- ✓ The elegant basement has a thick cover in ABS and grants high steadiness of the chair even at bed position.
- ✓ The backrest can be equipped with anatomical articulated head-rest that can be manually adjusted for more suitable height of the patient's head
- ✓ Removable swivel armrests in polyurethane that allow easy entrance of the patient by the side
- ✓ Equipped with FIXED FOOT-REST in chromed metal for a more comfortable patient seat



### MEDI-CARE SOLUTIONS S.R.L

SEDE LEGALE: Via Della Zecca N° 1 - 40121 Bologna (BO) Italy;  
SEDE OPERATIVA: Via Pietro Nenni 3 - 40026 Imola (BO)- Italy; Tel. ++39 0542 642046 Fax ++39 0542 642355

WEBSITE: [www.euroclinic.it](http://www.euroclinic.it) - E-MAIL: [info@euroclinic.it](mailto:info@euroclinic.it)

Capitale Sociale: € 50.000,00 i.v. - Iscrizione N° 03390661209 al Registro Imprese Bologna - P.I. e C.F. 03390661209  
R.E.A. N° 515493 - VAT 03390661209 - Registro AEE N° iscrizione IT5060000008925- N° MECC. BO056722

Azienda con Sistema di qualità certificato UNI EN ISO 9001:2015 and UNI EN ISO 13485:2021  
Company with Quality System Certificate UNI EN ISO 9001:2015 and UNI EN ISO 13485:2021

**ENT CHAIR Mod. OTOPV PROFESSIONAL 1 motor**



**ENT patient chair equipped with 1 LIFING COLUMN** operating the UP/DOWN movement for basic examination activity  
It is equipped with:

- compact structure in metal painted with epoxy powders in color white RAL 9003 complete with cover for basement in abs at high resistance
- legrest and backrest manually operated by gas spring lever
- reclining heavy metal plate as footrest on the leg support
- backrest reclines to bed position
- rotation of 360° with locking lever
- the upholstered parts of the chair are composed of high-density and undeformable foam pelted with bi-elastic, tear resistant, antimicrobial skai tissue, very easy to clean and disinfect. More than 40 different colours available
- **anatomical articulated head-rest** with manual adjustment in vertical and front direction set on the backrest
- removable and swivelling armrests in polyurethane for easy entrance of the patient by the side
- wide and stable metal basement painted in black colour

**MEDI-CARE SOLUTIONS S.R.L**

SEDE LEGALE: Via Della Zecca N° 1 - 40121 Bologna (BO) Italy;  
SEDE OPERATIVA: Via Pietro Nenni 3 - 40026 Imola (BO)- Italy; Tel. ++39 0542 642046 Fax ++39 0542 642355

WEBSITE: [www.euroclinic.it](http://www.euroclinic.it) - E-MAIL: [info@euroclinic.it](mailto:info@euroclinic.it)

Capitale Sociale: € 50.000,00 i.v. - Iscrizione N° 03390661209 al Registro Imprese Bologna - P.I. e C.F. 03390661209  
R.E.A. N° 515493 - VAT 03390661209 - Registro AEE N° iscrizione IT5060000008925- N° MECC. BO056722

**Azienda con Sistema di qualità certificato UNI EN ISO 9001:2015 and UNI EN ISO 13485:2021**  
**Company with Quality System Certificate UNI EN ISO 9001:2015 and UNI EN ISO 13485:2021**

## OTO P/i ELEGANCE



ENT chair equipped with **1 hydraulic pump system** operating the UP/DOWN movement  
It is equipped with:

- compact structure in metal painted with epoxy powders (colour white RAL 9003 or silver RAL 9006) complete with cover for basement in abs at high resistance
- backrest manually operated by gas spring lever and reclines max up to 120° for safety reasons
- fixed ring-shaped footrest
- rotation of 360° with locking pedal on the basement
- the upholstered parts of the chair are composed of high-density and undeformable foam pelted with bi-elastic, tear resistant, antimicrobial skai tissue, very easy to clean and disinfect. More than 40 different colours available
- **fixed headrest**
- anatomical articulated head-rest (OPTIONAL-to be confirmed) with manual adjustment in vertical and front direction set on the backrest
- removable and swivelling armrests in polyurethane for easy entrance of the patient by the side
- wide and stable metal basement painted in black colour

### MEDI-CARE SOLUTIONS S.R.L

SEDE LEGALE: Via Della Zecca N° 1 - 40121 Bologna (BO) Italy;  
SEDE OPERATIVA: Via Pietro Nenni 3 - 40026 Imola (BO)- Italy; Tel. ++39 0542 642046 Fax ++39 0542 642355

WEBSITE: [www.euroclinic.it](http://www.euroclinic.it) - E-MAIL: [info@euroclinic.it](mailto:info@euroclinic.it)

Capitale Sociale: € 50.000,00 i.v. - Iscrizione N° 03390661209 al Registro Imprese Bologna - P.I. e C.F. 03390661209  
R.E.A. N° 515493 - VAT 03390661209 - Registro AEE N° iscrizione IT506000008925- N° MECC. BO056722

Azienda con Sistema di qualità certificato UNI EN ISO 9001:2015 and UNI EN ISO 13485:2021  
Company with Quality System Certificate UNI EN ISO 9001:2015 and UNI EN ISO 13485:2021

**DOCTOR'S CHAIR SPD/A**



Doctor's chair mounted on 5 swivel castors (non-colouring to the floor), gas spring lift mechanism for seat height adjustment, 180 degree revolving and depth adjustable back rest.

The seat and the backrest are contoured for extra comfort; made of high density foam and covered with stain resistant material for easy cleaning.

It is durable, maintenance free, safe from tipping over and of ergonomic and comfortable design

- minimum height 530 mm
- maximum height 660 mm
- weight 13,70 kg
- base diameter 570 mm
- Ring foot rest diameter 420 mm

**MEDI-CARE SOLUTIONS S.R.L**

SEDE LEGALE: Via Della Zecca N° 1 - 40121 Bologna (BO) Italy;

SEDE OPERATIVA: Via Pietro Nenni 3 - 40026 Imola (BO)- Italy; Tel. ++39 0542 642046 Fax ++39 0542 642355

WEBSITE: [www.euroclinic.it](http://www.euroclinic.it) - E-MAIL: [info@euroclinic.it](mailto:info@euroclinic.it)

Capitale Sociale: € 50.000,00 i.v. - Iscrizione N° 03390661209 al Registro Imprese Bologna - P.I. e C.F. 03390661209  
R.E.A. N° 515493 - VAT 03390661209 - Registro AEE N° iscrizione IT506000008925- N° MECC. BO056722

**Azienda con Sistema di qualità certificato UNI EN ISO 9001:2015 and UNI EN ISO 13485:2021**  
**Company with Quality System Certificate UNI EN ISO 9001:2015 and UNI EN ISO 13485:2021**